

12R5.2

::Driver: olly jefferies ::Date: 18 dec

::Track: ardent raceway

::Event: EPS #2

Setup sheet for Team Associated's 12R5.2

::Front Suspension

Ride height: 3.7

Upper arm mounts: 0° 5° 10°



Camber: °tyres wear flat Toe: °0

Droop: very little, extra shim under spring for pre load

Bumpsteer shims: 2mm

King pin lube: none

Springs: 18 preloaded

Front Brace: None Soft Hard

Front width: kit, only 1 wheel washer used

Roll Center

Shims on top of the steering block: kit

Shims between bulkhead and caster block: 3mm

Notes:

::Front Tires

Brand & compound: jaco magenta

Diameter: 41.5mm

Wheel: jaco

Tire treatment: cs

Treatment time: 15minutes

Surface treated: just less than half

Notes:

clean tyre first with additive

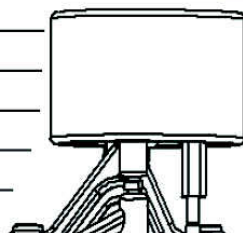

::Rear Suspension

Ride height adjuster: 2.5

Chassis ride height: 3.7

Pod ride height: 3.7

Droop: 1mm

Rear width: 171

Shims under pivot: -0.6

Center damper

Brand: ae

Spring: blue

Oil: 25

Position:

High Low

Side damper

Springs: green

Oil: 25



Shims: 2mm

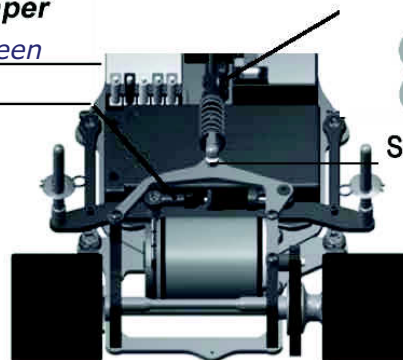

Notes:

::Rear Tires

Brand & compound: jaco magenta

Diameter: 43mm

Wheel: jaco

Tire treatment: cs

Treatment time: 15 minutes

Surface treated: full

Notes:

clean tyre first with additive

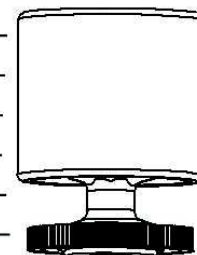

::Body

Brand & model: protoform amr lightweight

Notes:

::Motor / Battery

Motor: reedy sonic 3.5 Rotor: kit

Timing: 3 mark

Pinion: 25 Spur: 96

Rollout: 0.000

Battery: reedy #600

Plugs position: Front Back

::Speed Control

ESC: lrp sxx v2 firmware 1.7

Setting: 0863

::Transmitter

Turning Circle: 1.5 feet

Steering Expo: -15

Brake E.P.: 0

Throttle Expo: 0

Notes:

::Track Info

Composition: Asphalt Carpet

Surface: Smooth Bumpy

Traction: High Medium Low

Notes: